

5 Axle Crane / SPV Schematic for Conditional Registration

Operator Name & Company:

Intended Registered Address:

Chassis / VIN Number:

--	--	--	--	--	--	--	--	--	--	--	--	--	--	--	--	--	--	--	--

Approval Number on ID Plate: or N/A ← Circle if not applicable – **SUBMIT WITH HV INSP REPORT**

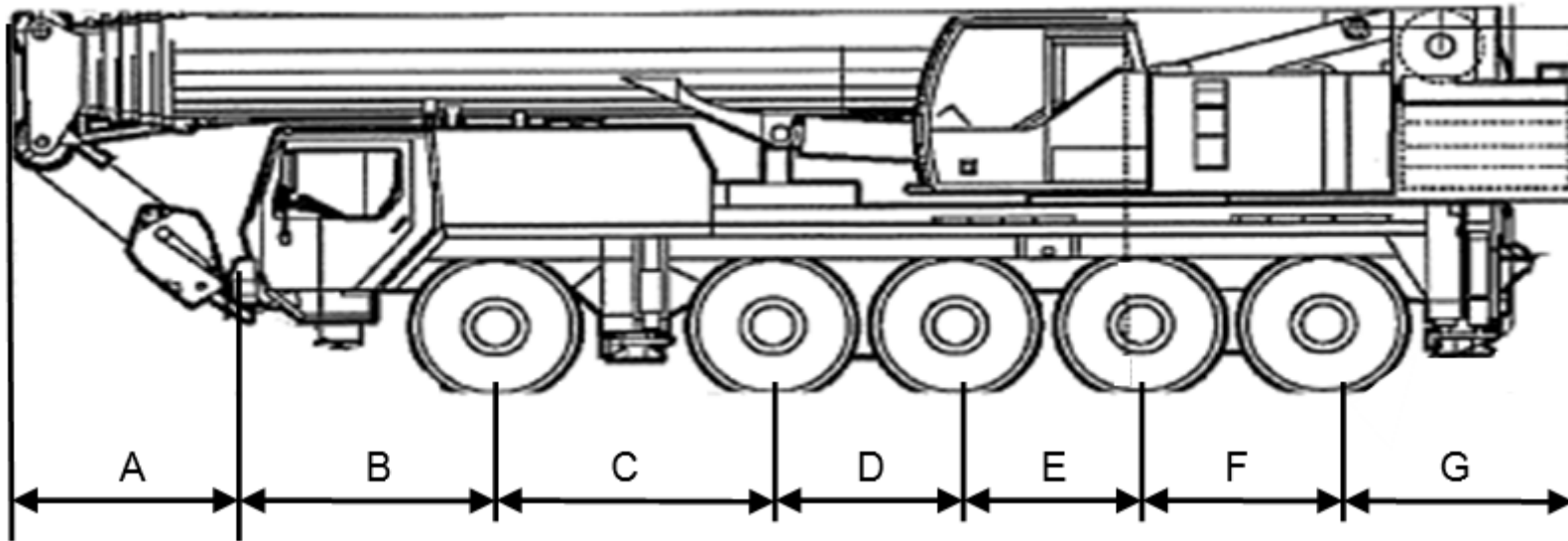

Insert axle spacings in metres below to two decimal points (e.g.2.35m)

A	B	C	D	E	F	G

Total Width:

Height:

Total Length:

AIS Stamp

VE..... Initials.....