

## 2 Axle Crane/SPV Schematic for Conditional Registration

**Operator Name & Company:** .....

**Intended Registered Address:** .....

**Chassis / VIN Number:**

|  |  |  |  |  |  |  |  |  |  |  |  |  |  |  |  |  |  |  |  |
|--|--|--|--|--|--|--|--|--|--|--|--|--|--|--|--|--|--|--|--|
|  |  |  |  |  |  |  |  |  |  |  |  |  |  |  |  |  |  |  |  |
|--|--|--|--|--|--|--|--|--|--|--|--|--|--|--|--|--|--|--|--|

**Approval Number on ID Plate:** ..... or **N/A** ← Circle if not applicable – **SUBMIT WITH HV INSP REPORT**

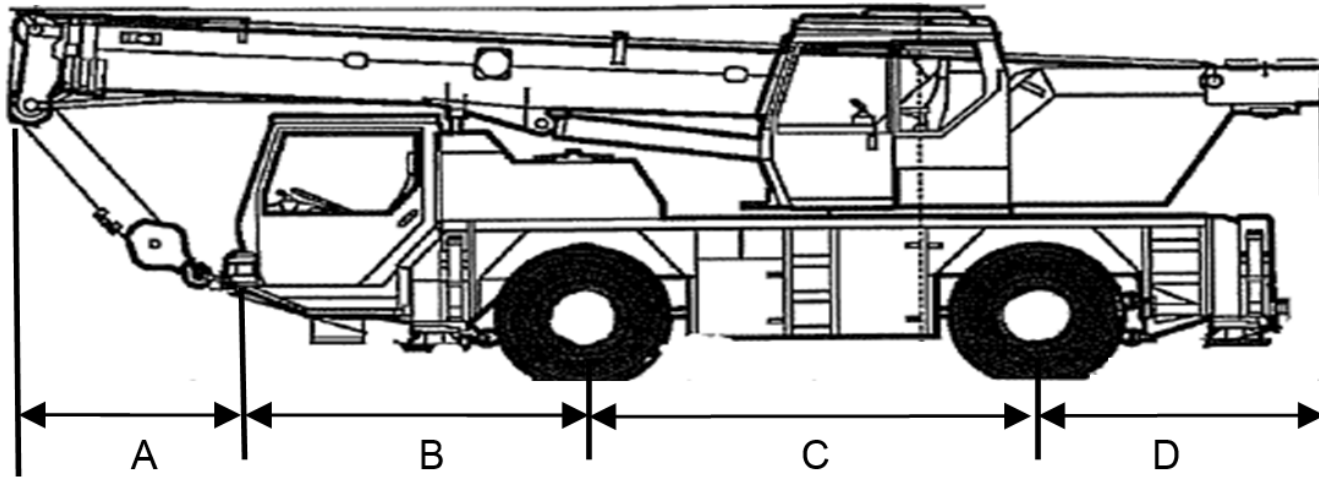

Insert axle spacings in metres below to two decimal points EG: 2.35m

| A | B | C | D |
|---|---|---|---|
|   |   |   |   |

**Total Width:** ..... **Height:** ..... **Total Length:** .....

**AIS Stamp**

VE..... Initials.....